

SUPERYACHT™

B U S I N E S S

Industry insight for decision makers



Overmarine

Building the Mangusta and its new displacement sister ship

Poland round-up

New build activity is booming — thanks to workers returning home with skills from Europe's top yards

Middle East

Industry prospects in the region look good — but only if major obstacles can be overcome



Ibiza investment

The €32m plan to create a superyacht party marina

Crew business

Leading agents reveal the challenges of finding good crew

Pirate threat

Armed Somalis are now targeting high value superyacht hostages



Vincenzo . Poerio

Benetti's long-serving CEO talks about his new role as head of the yard's Megayacht division

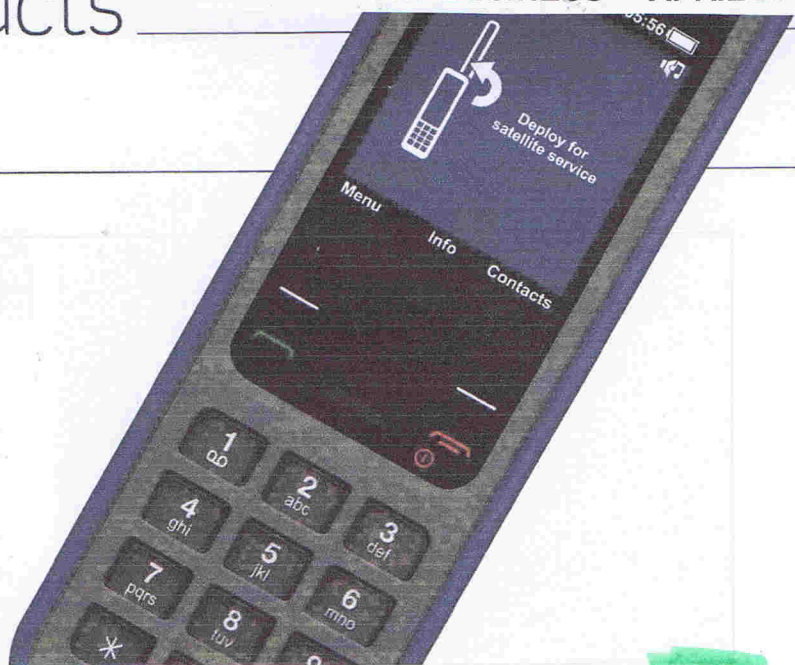
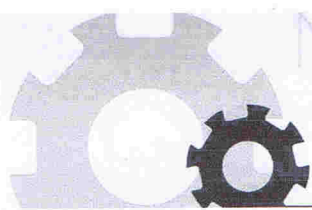

GLOBAL SATELLITE PHONE

► **Producer:** Global Telesat Communications

► **Web:** www.globaltelesat.co.uk

The IsatPhone Pro will perform anywhere in the world (with the exception of the Poles) and is supported by Inmarsat's global network coverage. Each crew member has their own SIM card for use with the phone and three post-paid airtime contracts are available: the Standard Plan, the Allowance 20 and Allowance 60.



HYDRAULIC TENDERLIFT

► **Producer:** Phoenix Marine Solutions

► **Web:** www.phoenixmarinesolutions.co.uk

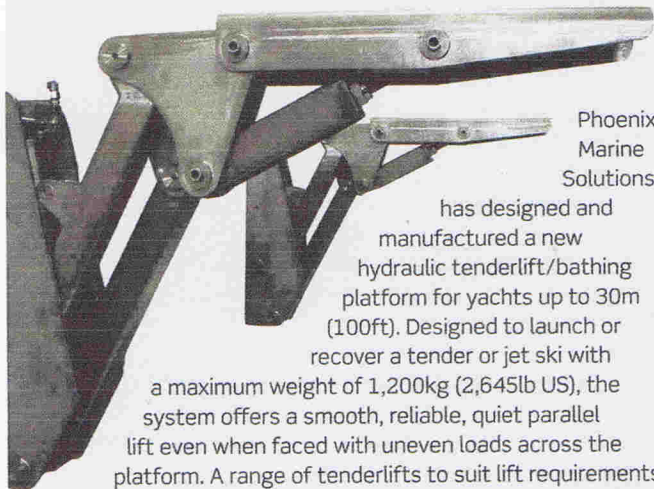

Phoenix Marine Solutions

has designed and manufactured a new hydraulic tenderlift/bathing platform for yachts up to 30m (100ft). Designed to launch or recover a tender or jet ski with a maximum weight of 1,200kg (2,645lb US), the system offers a smooth, reliable, quiet parallel lift even when faced with uneven loads across the platform. A range of tenderlifts to suit lift requirements of 600kg-2,000kg (1,322lb-4,409lb) is currently in development.



POD THRUSTERS

► **Producer:** CMC Marine

► **Web:** www.cmcmarine.com

Four new thruster models have been launched by CMC Marine, the Dualis BTM 20, 30, 40 and 50. They are designed to offer maximum flexibility thanks to the pod mounting block. Each thruster can be coupled to a hydraulic motor as well as an electric one. The new series has a wide range of units with power outputs ranging from 18kW (24hp) to 45kW (60hp).

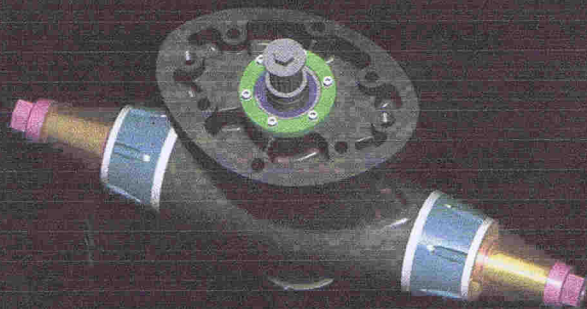

DESIGNER SOFA

► **Producer:** Aston Martin

► **Web:** www.astonmartin.com

The Aston Martin Sofa is part of the Aston Martin Interiors line, which is made in Italy by the Formitalia Luxury Group. The minimalist and futuristic design is inspired by the forms and curves that distinguish the cars made by the English automotive company. An inside frame made of steel and wood supports a lining made of natural leather with latex padding. The sofa lies on an external frame that is made of either aluminum with a satinised finish or carbon with a black finish.

